



Theory of soil compaction by running bodies of mountain tandem wheeled self-propelled chassis

R.M. Makharoblidze*, I.M. Lagvilvava, R.M. Khazhomia, B.B. Basilashvili

Agricultural University of Georgia, 240, David, Agmashebeli Ave., Tbilisi, 0159, Georgia

Received: 10 February 2019; accepted: 19 April 2019

ABSTRACT

The theory of soil compaction by running bodies an mountain tandem-wheeled self-propelled chassis is developed. Proceeding from the soil rheological properties and parameters of adaptive mountain tandem-wheeled self-propelled chassis in the deformation distribution zone is defined functional dependency between soil average density and running parts of tandem-wheeled self-propelled chassis. Is developed the technique of calculation of all physical values that are stipulated due standard for assessment of running system's parameters impact on ground. Due these parameters is stated the comparison of experimental and serial self-propelled chassis.

Keywords: Rheological models, Deformation depth, Equalizing beam suspension, Soil compaction, Chassis, Machine-tractor.

*Corresponding author: Revaz Makharoblidze; E-mail: r.makharoblidze@arguni.edu.ge

Introduction

Density represents one of the most important characteristics of the soil. For different crops value of optimal density is in a rather narrow range (for grain - 1.1 ... 1.3 g/cm³ for the row - 1.1 ... 1.5 g/cm³). Due to the impact of mobile members of machine-tractor units on the soil increases its density in the plow and subsurface horizons that leads to serious changes in the soil structure and characteristics, deterioration of root system's habitation and, ultimately, in lower crop yields [1].

Nowadays in the field of agricultural production mechanization occurs a gradual transition to an intensive and high technology machine crop technologies that cause the complication of machinery, extension of their functionality, increase in capacity, and as a result, increasing of weight, number of passes and speed of movement on the fields. In the process of soil preparation, planting, plant care and harvesting various machines are passing through the field from 5 to 15 times, resulting in the total area of vehicles propulsion tracks of 2 times exceed the size of field, the 10 ... 12% of field area are undergoing propeller impact of 6 up to 20 times, 65 ...

80% - from 1 to 6 times and only 10 ... 15% of the area is not compacted by machines [1].

It was defined that as a result of machine-tractor unit's passage on the field in the soil are created large-sized compaction zones, concentrating around the tracks of running bodies and extending to a distance of 0.8 ... 1.0 m on either side of the tracks of caterpillars or wheels. On depth these zones are extended to the whole topsoil and reach 0.6 m [1].

As a result of multiple impacts of propulsion, as well as tillage tools occurs an accumulation of compaction deformations not only in the plow, but also in the subsurface layer of soil that is harmful to fertility. The resulting plow sole prevents the water penetration into the soil, leads to water erosion, or to its rapid drying and wind erosion during drought. Plow sole violates the capillary flow of moisture from the deeper layers to the surface and prevents the development of root system. The destruction of plow sole is using chisel plows or chisels that significantly improve the soil fertility, but raise the price of technological process.

Recently the reducing of compaction effect impact on soil by agricultural machinery propellers occurs in three ways [1].

Technological way consists in improving the crops cultivation technology, including reducing the number of passes, a rational of routing machines movement, application combined and wide-cut units, minimum tillage, arrangement of permanent travel lanes for vehicles, application of overload technology in the interaction with vehicles, etc.

Agronomical way consists in increasing the soil capacity to resist compaction and shear loadings due organic fertilizers application, mulching, and keeping the all quality indicators for soil cultivation, the introduction of additional decompression operations.

Design way that consist in the improvement of tractors, agricultural machinery and their propulsion in the direction of eliminating or reducing harmful effects on the soil.

A certain reducing of on the soil would be achieved by increasing of tires size, but simultaneously are compacted the deeper layers of soil. The perspective would be the application of multi-axis tractors in order to reduce pressure on soil, and consequently, it compaction [2]. This would be achieved without increasing the number of tractor axles, by setting on the rear drive axle of tandem wheels suspension equalizer. This self-propelled chassis can be given also adaptive properties to expand their application scopes in small farms [3].

Basic part

The schematic diagram of the adaptive self-propelled chassis is shown in Fig. A.

With regard to running bodies of this energy means theory of soil compaction requires significant improvements with application of rheological models of soil deformation.

For the averaged estimation assessment of the soil density on the tractor trail with an area F we can write down:

$$\rho = \frac{M}{F(H^* - h)} = \frac{M}{FH^* \left(1 - \frac{h}{H^*}\right)} = \frac{\rho_0}{1 - \varepsilon}, \quad (1)$$

where M - is the mass of the soil compacting layer, kg;
 H* - is the depth of deformation distribution, m;
 h - is the depth of gauge, m;
 ρ0 - is the soil initial density, kg/m3;
 ε - is the relative deformation.

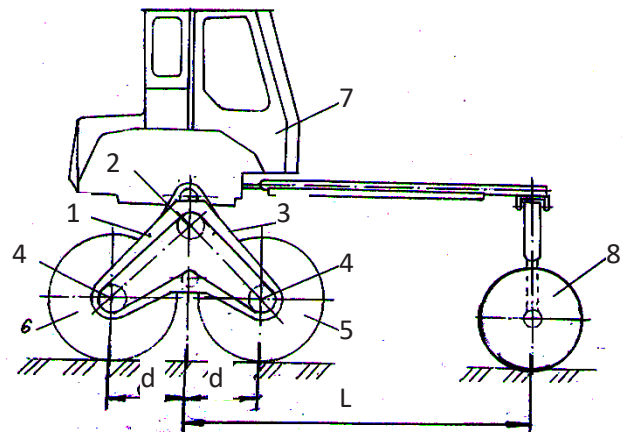

Fig. Schematic diagram of the adaptive self-propelled chassis.

1-balancer gear; 2-drive axis; 3-chain transmission; 4- drive wheels axis; 5-front drive tandem wheel; 6-rear drive the tandem wheels; 7-propelled chassis, 8-front wheels.

With the application of Voigt rheological model we obtained a design formula of gauge relative deformation after the passage of the three wheels of adaptive self-propelled chassis in the following form [4].

$$\varepsilon = \frac{G_g}{3F_0H} \left(1 - e^{-\frac{\ell}{\tau v}}\right) \left(1 + e^{-\frac{2d}{\tau v}} + e^{-\frac{L+d}{\tau v}}\right), \quad (2)$$

and with the application of general law of linear deformation equation

$$\varepsilon = \frac{G_g}{3F_0} \left[\frac{1}{E} + \left(\frac{1}{H} - \frac{1}{E}\right) \left(1 - e^{-\frac{\ell}{\tau v}}\right) \left(1 + e^{-\frac{2d}{\tau v}} + e^{-\frac{L+d}{\tau v}}\right) \right], \quad (3)$$

where G_g - is the total weight of self-propelled chassis, N;

S - is the instantaneous modulus of elasticity, N/m²;

H - is the long-term modulus of elasticity, N/m²;

$\tau = \frac{\mu}{H}$ - is the deformation delay time or time, s;

μ - is the coefficient of viscosity, N.s/m2;

ℓ - is the length of propeller bearing surface, m;

F0 - is the average area of wheels contact with the ground, m2.

At $\frac{1}{E} \approx 0$ the design formulas (2) and (3) coincide. For example, substituting in (1) the expression (2) we obtain the averaged soil density on the tractor trail in the following form:

$$\rho = \frac{\rho_0}{1 - \frac{G_g}{3F_0H} \left(1 - e^{-\frac{\ell}{\tau v}}\right) \left(1 + e^{-\frac{2d}{\tau v}} + e^{-\frac{L+d}{\tau v}}\right)} \cdot \quad (4)$$

In terms of herbage conservation, the criterion for the compaction effects on soil is not the averaged density but the soil density in the propeller's trail [5]:

$$\rho_t = \rho_0 + \alpha U, \tag{5}$$

$$\alpha = \frac{\rho_0(1-\nu^2)}{E_0 H^*}, \quad U = \omega b^* q_{\max} (1 + \ell_g n). \tag{6}$$

where H^* – is the deformation distribution depth, m;
 ν – is the coefficient of lateral expansion (Poisson ratio);
 E_0 – is the module of total deformation, N/m²;
 ω – is the coefficient depending on the size and shape of the propeller bearing surface (For wheeled propeller $\omega = 1.25$ [1]);
 b^* - is the width of single propeller trail, m;
 q_{\max} – is the maximum pressure on soil, N/m².
 For the wheel of system:

$$q_a = \frac{M \cdot g}{\sum_{i=1}^n F_i}, \tag{7}$$

where n - is the number of wheels on one track;
 M – is the mass of tractor.

It was defined that allowable propeller impact without crop yields decreasing is in the range $U < 75$ kN/m that is equivalent to the soil moisture at 25 ... 30% $q_{\max} \leq 0.075$ MPa, and at 8 ... 12% - $q_{\max} \leq 0.15$ MPa [1].

In the design formulae (5) and (6) the unknown quantity is the depth of deformation distribution H^* . As it is known, the relative deformation $\varepsilon = \frac{h}{H^*}$, i.e. $H^* = \frac{h}{\varepsilon}$. With consideration of the unit movement speed, soil rheological properties, as well as wheel geometrical and loading parameters, is obtained the expression for determining the depth of gauge at one wheel [6]:

$$h = \sqrt[3]{\frac{G^2}{b^2 K^2 D}} \cdot \sqrt[3]{\left[\frac{1 + (\tau \omega_0)^2}{1 + (2\tau \omega_0)^2} \right]^2}, \tag{8}$$

where G – is the load on wheel, N;
 D – is the diameter of wheel, m;
 b – is the width of wheel, m;
 K – is the coefficient of volume collapse, N/m³;
 τ – is the soil relaxation time, sec;
 ω_0 – is the angular velocity of wheel, 1/sec.

At increasing of re-loading to a value that precedes it, the wheels subsidence occurs, as at the re-deformation, by the same load. The further growth of re-load causes deformation of the deeper layers of soil, at this occurs the subsidence, as in the first loading or it slightly decreases because of the upper layers compaction. The impact reducing would be estimated by the factor K_L [2]:

$$K_L = 1 - \left(\frac{q_i}{q_{i+1}} \right)^{2n'} \tag{9}$$

where q_i and q_{i+1} – are the pressure values at previous and subsequent loadings, N/m²;
 n' – is the trial coefficient.

Then the dependence of subsidence on the various values of wheels pressures for consecutive arranged three-wheel self-propelled chassis would be written down as:

$$h = \sqrt[3]{\left[\frac{1 + (\tau \omega_0)^2}{1 + (2\tau \omega_0)^2} \right]^2} \cdot \frac{\left[\sqrt[3]{G_1^2 + \sqrt[3]{G_2^2} \left(1 - \frac{q_1}{q_2}\right)^{2n'}} + \sqrt[3]{G_3} \left(1 - \frac{q_2}{q_3}\right)^{2n'} \right]}{\sqrt[3]{b^2 K^2 D}}. \tag{10}$$

At loading decreasing from the passage to the passage the soil gauge depth is determined by the pressure developed during the first pass. At the same load on all wheels magnification factor of wheel is estimated by [1]:

$$K_0 = 1 + \ell_g n. \tag{11}$$

Then the dependence of subsidence on pressure of consecutive arranged three-wheel self-propelled chassis will be as:

$$h = \sqrt[3]{\frac{G^2}{b^2 K^2 D}} \cdot \sqrt[3]{\left[\frac{1 + (\tau \omega_0)^2}{1 + (2\tau \omega_0)^2} \right]^2} (1 + \ell_n 3),$$

or

$$h = 1,477 \sqrt[3]{\frac{G^2}{b^2 K^2 D}} \cdot \sqrt[3]{\left[\frac{1 + (\tau \omega_0)^2}{1 + (2\tau \omega_0)^2} \right]^2}. \tag{12}$$

At load decreasing on the passage to the passage the soil gauge depth is determined by the pressure developed during at the first pass, i.e. by expression (8).

We obtain that for a self-propelled chassis with equalizing beam suspension of two driving wheels the depth of deformation distribution in Voight rhe-

ological model is defined by:

$$H^* = \frac{h}{\varepsilon} = \frac{1,477 \sqrt[3]{\frac{G^2}{b^2 K^2 D}} \cdot \sqrt[3]{\left[\frac{1+(\tau\omega_0)^2}{1+(2\tau\omega_0)^2}\right]^2}}{\frac{G_g}{3F_0 H} \left(1 - e^{-\frac{\ell}{\tau v}}\right) \left(1 + e^{-\frac{2d}{\tau v}} + e^{-\frac{L+d}{\tau v}}\right)} \quad (13)$$

Similarly, when using the rheological model of the general law of linear deformation, we obtain:

$$H^* = \frac{1,477 \sqrt[3]{\frac{G^2}{b^2 K^2 D}} \cdot \sqrt[3]{\left[\frac{1+(\tau\omega_0)^2}{1+(2\tau\omega_0)^2}\right]^2}}{\frac{G_g}{3F_0} \left[\frac{1}{E} + \left(\frac{1}{H} - \frac{1}{E}\right) \left(1 - e^{-\frac{\ell}{\tau v}}\right) \left(1 + e^{-\frac{2d}{\tau v}} + e^{-\frac{L+d}{\tau v}}\right)\right]} \quad (14)$$

At $\frac{1}{E} \approx 0$ formulae (13) and (14) are coincide.

The depth of deformation distribution for a commercial self-propelled chassis with application of Voigt model and results of the study [3] would be:

$$H_s = \frac{1,301 \sqrt[3]{\frac{G^2}{b^2 K^2 D}} \cdot \sqrt[3]{\left[\frac{1+(\tau\omega_0)^2}{1+(2\tau\omega_0)^2}\right]^2}}{\frac{G_g}{2F_0 H} \left(1 - e^{-\frac{\ell}{\tau v}}\right) \left(1 + e^{-\frac{L}{\tau v}}\right)} \quad (15)$$

At the same load on the wheel, the depth of deformation distribution for mountain self-propelled chassis would be increased on the value of:

$$K = \frac{H^*}{H_s} = 1,704 \frac{1 + e^{-\frac{L}{\tau v}}}{1 + e^{-\frac{2d}{\tau v}} + e^{-\frac{L+d}{\tau v}}} \quad (16)$$

For example, let's assume that: $\tau=1\text{m}$; $L=2.55\text{m}$; $d=0.546\text{m}$; $\ell=0.29\text{ m}$; $v=5\text{ km/h} = 1.39\text{ m/sec}$; $G_g=23100\text{ N}$; $G_a=3850\text{ N}$; $b=0.5\text{ m}$; $D=0.71\text{ m}$; $K=2500\text{ kN/m}^3$; $H \approx E=2 \cdot 10^5\text{ N/m}^2$; $\omega=1.25$; $q_{\text{max}}=1.5q_a=161\text{ kN/m}^2$. We obtain: $K = 1.28$, $h \approx 0.05\text{ m}$ (formula 8); $\varepsilon \approx 0.05$ (formula 2), $H^* = \frac{h}{\varepsilon} \approx 1\text{ m}$; $\omega=29.756\text{ kN/m}$ (formula 6); $\rho/\rho_0=1.053$ (formula 5).

Due to the increasing in deformation distribution depth H^* the value of α in the formula (6) will be decreased. Also would be reduced the maximum pressure q_{max} on the wheels because increased number of wheels. As a result, significantly would be reduced the soil density in the propeller trail ρ_i . According to the formula (5), by adjusting the of self-propelled chassis parameters the soil density in the propeller

trail ρ_i and propeller impact without crop yields reducing would be improved to the optimum value in terms of grass cover keeping.

Conclusion

The theory of soil compaction by running bodies of mountain tandem-wheeled self-propelled chassis is developed. Are defined functional dependency between soil average density in the soil deformation distribution zone and soil density in the propeller trail on rheological properties of soil and parameters of adaptive self-propelled chassis. The method of all physical values calculation that are needed to evaluate the assessment of impact indicators of running system on ground by standards is developed. According to these indicators is given the comparison of experimental and commercial self-propelled chassis.

References

- [1] Zabrodsky V.M., Fainleib A.M., Kutin L.N., Utkin-Lyubovtsev O.L., Running the System Tractors, Agropromizdat, Moscow, 1986 (in Russian).
- [2] Katsygin V.V., Gorin, G.S., Perspective and other mobile power tools. Minsk: Science and technology, Minsk, 1982 (in Russian).
- [3] Makharoblidze R.M., Basilashvili B.B., Lagvilava I.M., Makharoblidze Z.K., General principles for the development of adaptive self-propelled chassis for farm facilities, In: Scientific and technical progress in the engineering field of agricultural sector, Georgia, Tbilisi, 1999, pp. 19-22 (in Georgian).
- [4] Maharoblidzk R.M., Lagvilava I.M., Asatiani O.G., Kobakhidze A.B., Interaction with the soil of adaptive self-propelled chassis suspension system, In: Proceedings of the Academy of Agricultural Sciences, Tbilisi, 2010, pp. 27-29 (in Georgian).
- [5] Makharoblidze R.M., Methods of Theory of Impact and Rheology in Agricultural Mechanics, Intellecti, Tbilisi, 2006 (in Georgian).
- [6] Karapetyan M.A., The soil deformation by caterpillar mover, J. of MESKh, 6 (2007) 27-29 (in Russian).